

PRECISE. INNOVATIVE. LEADING.
ASSEMBLY AND TEST STANDS

GENERAL INFORMATION

The Woodward L'Orange assembly and test stand unit is designed for servicing fuel injection valves of medium-speed diesel engines. It combines assembly device, test stand and booster in a single unit and is also ideally suited for assembly and testing work on injection pumps, safety

valves and similar precision components that require special care. This means that the mechanical expert can carry out servicing work in the most efficient manner possible, since the unit was designed for perfect functionality as well as easy, clean handling.

ASSEMBLY AND TEST STAND

The high performance high-pressure test pump, booster and test oil tank are securely mounted inside the unit. The integration of an evacuation feature to the plexiglass spray container enables better observation of the nozzle holes and fuel jets.

DESCRIPTION OF COMPONENTS

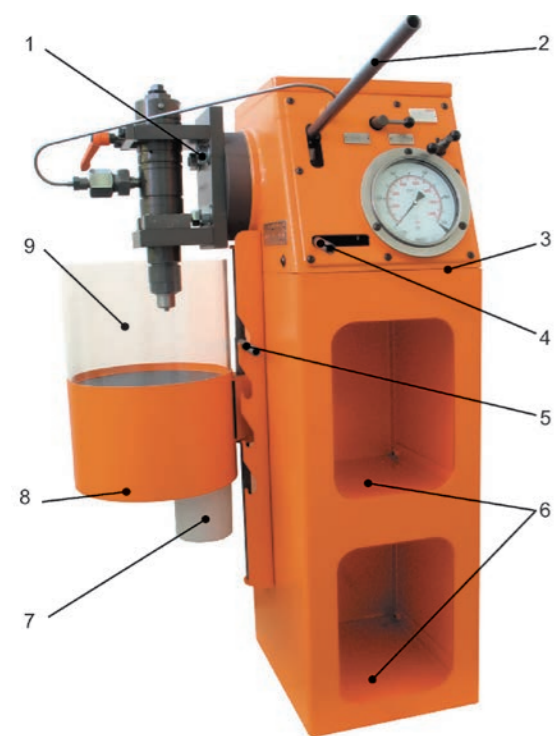

- 1 Fixation for mounting device (with two different pitch circle diameters)
- 2 Lever for pumping
- 3 Partition of test rig in tabletop (GXO-G011a) and ground based (GXO-G010a)
- 4 Lever with locking mechanism for rotating the mounting device
- 5 Device to move showcase upwards and downwards
- 6 Pockets for mounting devices and tools for example
- 7 Oil collecting tank
- 8 Fan to evacuate oil vapour
- 9 Showcase to watch spray pattern during the function test

YOUR BENEFITS, DESIGN ADVANTAGES AND NEW FEATURES

Benefits:

- One device, three functions
- Efficient servicing work
- Ergonomic working position

Design advantages:

- Disassembly, cleaning, assembly and testing are possible in one tightening
- 360° rotation of the valve possible
- To justify safety requirements, the device is lockable every 22.5°
- The pressure gauge (Ø 160 mm) can be observed simultaneously with the spray pattern during the function test.

New features:

- Booster, tank and filter in a single unit
- Evacuation of oil vapour
- Assembly of clamping brackets GUO/GXO without modification
- Pressure relief lever
- Switch-over between pressure wave generation and opening pressure testing
- Pressure release/safety valve opens at 900 bar

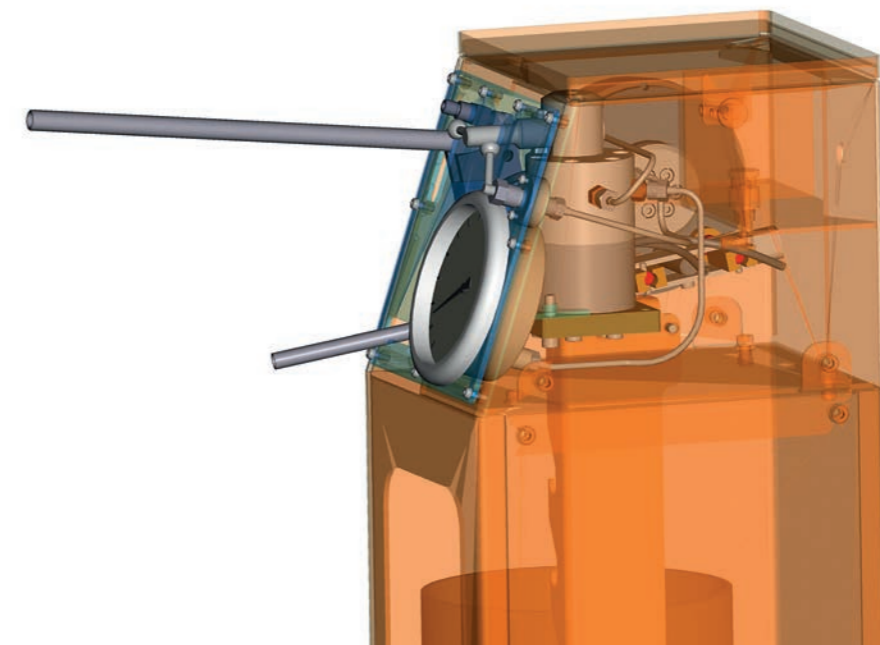

WOODWARD INC.

LINCOLN CAMPUS CORPORATE HEADQUARTERS
1081 WOODWARD WAY, FORT COLLINS, COLORADO 80524, USA
WWW.WOODWARD.COM

WOODWARD L'ORANGE GMBH

PORSCHESTRASSE 8, 70435 STUTTGART, GERMANY
TEL. +49 711 82609-0, WWW.LORANGE.COM